

# **SCREW AIR COMPRESSOR**

**TYPE: MAM-880 ( B )**

**USER**

**MANUAL**

## **Shenzhen Plot electronic Co., Ltd**

Address: Sixth floor, twenty fifth building, TIAN JIAN industrial estate,  
SHANG BAO road; FU TIAN district; SHEN ZHEN

Telephone: (0755) 83172098 83172068 Postal code: 518034

Fax: (0755) 83172966 E-mail: [plt@pltsz.com](mailto:plt@pltsz.com)

Web site: [www.pltsz.com](http://www.pltsz.com)

## NOTICE



Please read instruction manual before usage



Installation of MAM—8\*\* can be performed only by professional technicians



Assembling position shall be considered carefully during mechanical installation in order to ensure good heat dissipation and reduce electromagnetism interferences



Wiring shall be performed respectively according to regulations for heavy and weak current to reduce electromagnetism interferences



Surge absorber must be communicated with inductive load such as AC contactor of output control of relay



Output wiring shall be inspected carefully before switch up



Earthing terminal of this body part shall be earthed correctly (the third type of earthing) to increase product's capacity of resisting signal noise.



Motor's rated current (current for stopping instrument automatically) shall be set according to rated current indicated on motor's name plate  $\times$  overload current multiplication factor of motor/ 1.2

### Features:

- LCD Chinese / English display
- With control functions of starting, stopping and operation for motor.
- With protection functions of preventing reverse rotation of air compressor.
- Temperature measurement and control
- Automatic adjusting of rate of load and controlling of pressure balance
- Selections of remote and local control
- Selections of interlocking and independent
- Function of RS485 communication

1、 Basic Operation .....	4
1、 Button Explanation .....	4
2、 Indicator instructions .....	4
3、 Display of status and operations .....	5
4、 Operating parameters .....	5
5、 User Parameter (Customer Parameter): .....	6
6、 Customer Parameter and Functions .....	7
7、 Factory Parameters .....	9
8、 Manufacturers and function .....	9
9、 Calibration parameters .....	10
10、 the operating authority and password .....	12
2、 Technical parameters and functions .....	12
3、 Type and specification .....	13
1、 Instruction of type .....	13
2、 Specification table for power of suited motor .....	13
4、 Installation .....	14
1、 Installation of transducer .....	14
2、 Controller Installation .....	15
3、 Terminal arrangement diagram .....	15
5、 Control principles .....	16
1、 Local Automatic control .....	16
2、 Remote automatic control .....	17
3、 Local manual control .....	17
4、 Remote Manual Control .....	17
5、 Network control .....	17
6、 Temperature control of fan .....	18
7、 Failure shutdown and emergency shutdown .....	18
6、 Early-warning and prompts .....	18
1、 Indication of early warning of oil filter .....	18
2、 Indication of early warning for air filter .....	18
3、 Indication of early warning for oil separator .....	18
4、 Indication of early warning for lubricating oil .....	18
5、 Indication of early warning for grease .....	18
6、 Indication of early warning for belt .....	18
7、 High air temperature warning .....	18
7、 Controller protection .....	19
1、 Motor protection .....	19
2、 Gas Exhaust Over-temperature Protection .....	19
3、 Non-reversing Protection of Air Compressor .....	19
4、 Overpressure Protection of Pressure Supply .....	19
5、 Malfunction Protection of Sensor .....	19
8、 Removal of Common Failures .....	19
1、 Failures Review .....	19
2、 Common Failures and Causes .....	20
9、 Electrical diagram .....	20

# 1、 Basic Operation

## 1、 Button Explanation

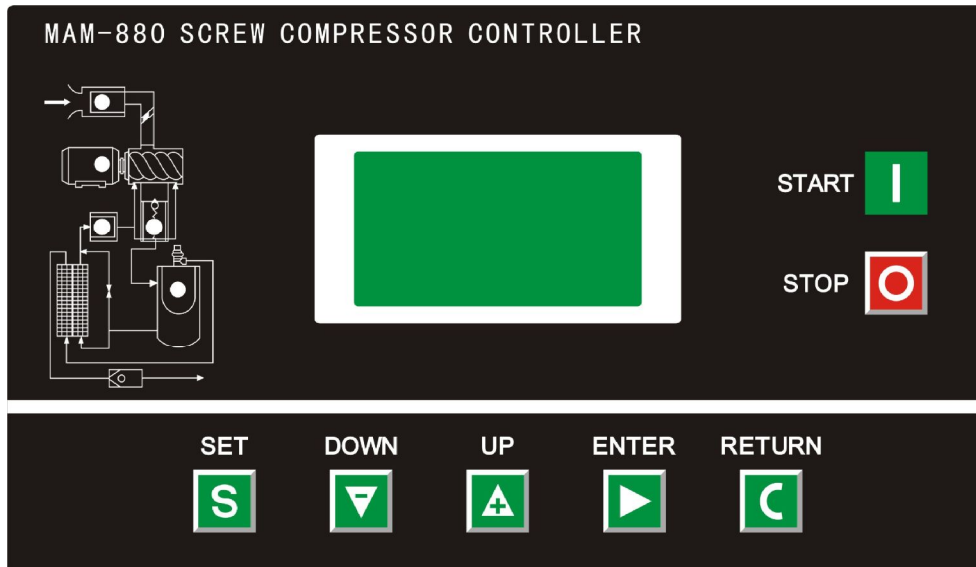

Figure 1.1.1



Start Button: Press this button to start the compressor.



Stop button: Press this button to stop the compressor.



Set Button/ Loading / unloading Button: After modification, press this to confirm and save modified data; When the compressor is running ,press this button to load or unload under a certain pressure.



Move up button/increase button: Data at current position is increased by pressing this button when data are modified; Menu is moved upwards when menu is selected.



Move down button / Descending button: Data at current position is descended by pressing this button when data are modified; menu is moved downwards when menu is selected.



Shift button /Enter button: This button services as shift button when data are modified and services as enter button when menu is selected.



Back button / Reset button: This button services as back button when operate menu to come back Parent menu; resetting is carried out by pressing this button for a little long time when failure shutdowns

## 2、 Indicator instructions

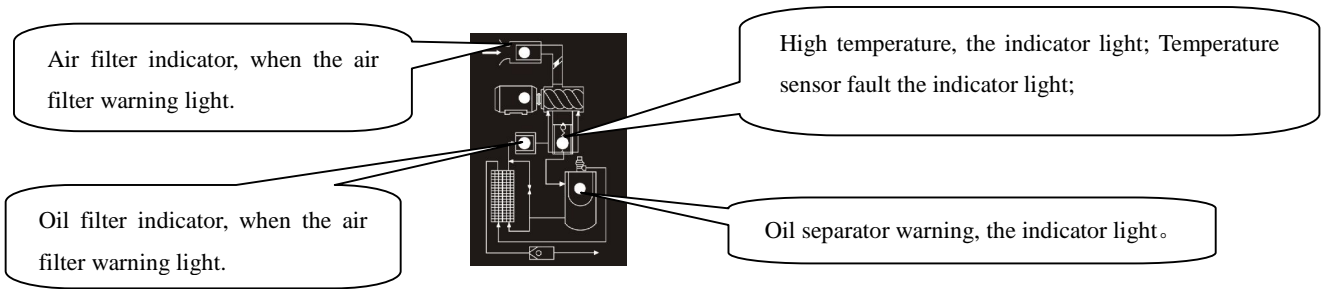

### 3、Display of status and operations

The display screen will be as follow when the units are powered on:

WELCOME USING  
SCREW COMPRESSOR

← After power on, screen show this page

After 5 seconds, the main page will show up as:

AIR T: 20°C  
AIR P: 0.60MPA  
NORMAL STOP  
C001      REMOTE

← Main page

Press “Move down button” to enter into Menu Selection Interface:

**RUN PARA.**  
USER PARA.  
FACTORY PARA.  
CALBR PARA.

← Level 1 menu screen

### 4、Operating parameters

Press “Move down button” or “Move up button” to move the black cursor to “RUN PARAMETER”, press enter button to pop up submenu:

**MOTER FAN CUR**  
TOTAL RUN TIME  
THIS RUN TIME  
MAINTAIN PARA.

HISTORY FAULT  
SERIAL NUMBER  
THIS FAULT  
COM STATUS

Move the scroll bar to the corresponding menu item, press the enter key, see the specific parameters. Such as view, "MOTER FAN CUR " move the scroll bar to the " MOTER FAN CUR " menu item, press the enter key, switch to the motor and fan current interface

MAIN (A)	FAN (A)
A 50.1	2.1
B 50.1	2.1
C 50.1	2.1

If the menu popped up is at the last level, the black cursor will disappear. Press the return button to return to the upper menu or the main page. If the operation stops at a certain page, it will automatically return to the main page after 60 Seconds

### 5、User Parameter (Customer Parameter) :

In primary menu,, press the move button to move the black slider to the "USER PARA." menu, press the shift button to switch to the following menu:

<b>P、 T SET</b>
TIME SET
OPERATION MODE
SEQ PARA. SET

CLR LIFE TIME
MAX LIFE TIME
LAN. SEL:EN
NEW USER PIN: ****

Move the cursor to the "P、 T SET " menu, then press enter button to switch to the following interface:

<b>LOAD P: 00.62 MPa</b>
UNLOAD P: 00.78MPa
FAN START: 0080°C
FAN STOP: 0075°C

Move the cursor to the "LOAD P" menu, Press enter button , Switch to the following interface requirements to enter a user password

INPUT CODE
****

After showing this interface, The first bit data or password started flashing, press "increase button" or "descending button" to modify the flashing data equal

to the first bit of password, Press the shift button, move the cursor to the next data bit, modify the current data is equal to the second password data, Accordance with the above , modify the third and fourth Finally, press the “Set button” to confirm the input, the system verify the password is correct, switch to the following interface:

<b>LOAD P: 00.62 MPa *</b>
UNLOAD P: 00.78MPa
FAN START: 0080℃
FAN STOP: 0075℃

The upper right corner with "\*" prompt said the system has passed the password authentication

In as shown above interface, press “enter button” , then the data of loading pressure start to flash, users can press “increase button” or “Descending button” to modify the present data. When finished, press “Set Button” to confirm and save. the controller prompt sends out the short voice to tip.

## 6、Customer Parameter and Functions

First Submenu	Second submenu	Preset Value	Functions
SET P. T.	LOAD P.	*.**MPa	LOADING PRESSURE VALUE
	UNLOAD P.	*.**Mpa	UNLOADING PRESSURE VALUE
	FAN START	***℃	Control the fan starting. This value will be set as “120℃” if there is no fan present or the fan is not required to be protected.”
	FAN STOP	***℃	Control the stopping of the fan
TIME SET	HOST START	0008S	When using the controller to protect the motor, it is required that the time set here will not meet the impulse starting current of the motor, the value here must be longer than the STAR DELAY TIME plus LOAD DELAY TIME
	FAN START	0006S	When using the controller to protect the motor, it is required that the time set here will not meet the impulse starting current of the motor.
	STAR DELAY	0006S	Star pressure descending start delay time.
	LOAD DELAY	0002S	The loading delay time after star pressure descending.
	EMPTY DELAY	0020M	Load free continuous running time, the machine will automatically stop after this time
	STOP DELAY	0010S	The machine will not stop until the load free running status lasting till this time
OPERATION MODE	START DELAY	0100S	Machine can not be restarted before this set time after stopped or over time operation at load free state
	ON/OFF MODE	NEAR/FAR	When the remote mode is set, both the button on the controller and the remote control button can turn on and off the machines;When the near mode is set,only the button on the controller can turn on and off the machines.

	LOAD MODE	AUTO/MANU	When the manual mode is set, the Load/Unload function can only be executed by pressing “load/unload” button
	COM MODE	BAN/COMP./BLOCK	When this is set as “BAN” the communication function is not available When this is set as “COMP.” the Controller as a slave, in accordance with MODBUS protocol communications with external devices When this is set block, block control active
	COM ADD	0255	Communication address
BLOCKING MODE	SEQ STATE	SLAVE	Service as main or assistant air compressor during interlocking operation. The MAIN controls the SLAVE
	TURN TIME	9999 Hours	During interlocking operation, if one air compressor continuously operates for time period more than time set here and rest time of one air compressor in interlocking network has reached the time set here, alternative rest is achieved by starting the resting air compressor and stopping the operating air compressor
	SEQ NUMER	0016	Number of air compressors in interlocking network during interlocking operation
	SEQ LOAD	*.**MPa	The main air compressor searches for one device in the interlocking network for loading or starting when main air compressor’s gas supply pressure is less than the value set here during interlocking operation
	SEQ U.L.	*.**MPa	The main air compressor searches for one device in the interlocking network for unloading or stopping when main air compressor’s gas supply pressure is more than the value set here during interlocking operation
	SEQ DELAY	0030S	The least waiting time that the main air compressor needs to continuously sends control commands two time
CLR LIFE TIME	OIL FILTER	0000H	Reset time for the duration of oil filter changing
	O/A FILTER	0000H	Reset time for O/G Separator changing
	AIR FILTER	0000H	Reset time for gas filter changing
	LUBE	0000H	Reset time for Lubricate Oil Changing
	GREASE	0000H	Reset time for Lubricate Grease Changing
	BELT	0000H	Reset time for Belt Grease Changing
MAX LIFE TIME	OIL FILTER	9999H	Set this value to “0” will make the oil filter alarm not available
	O/A SEPARATOR	9999H	Set this value to “0” to disable the O/G separator alarm function
	AIR FILTER	9999H	Set this value to “0” to disable the alarm function of gas filter



	LUB	9999H	Set this value to "0" to disable the time alarm of lub. oil
	GREASE	9999H	Set this value to "0" to disable the time alarm of Lub. Grease
	BELT	9999H	Set this value to "0" to disable the time alarm of belt.
LANG.SEL	EN/CH	EN	Set this value to "EN" , Display text in English Set this value to "CH" , Display text in Chinese
NEW USER PIN	****	****	Customer could modify the user password

## 7、 Factory Parameters

The factory parameters can be looked over and modified with manufacturer password, but its operation method is the same as that of user parameters. Please refer to following table for main functions and purposes.

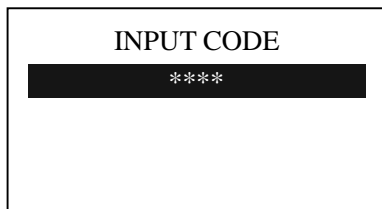

Manufacturers enter the correct password, press set button, switch to the factory parameters of the interface as follows

MOTOR CUR: 100.0A
FAN CUR: 010.0A
ALARM T: 0105°C
STOP T: 0110°C

STOP P: 00.90MPa
MAX U.L.: 00.85MPa
RUN TIME: 001234H
LOAD TIME: 001001H

.....  
Factory parameters "run time", "phase sequence protection," "Frequency Selection" and the time need check super password to changes.

## 8、 Manufacturers and function

PARAMETER	Initial Value	Functions
MOTOR CUR	MAXIMUM OVERLOAD VAULE OF THE MOTOR /1.2	After the starting delay time, when the motor current is greater than 1.2 times of the set value and less than 4 times of the set value, the unit will jump as per overload feature.
FAN CUR	Maximum allowable motor overload value/1.2	Same as above
ALARM T.	105°C	Pre-alarm when the temperature reaches this set value
STOP T.	110°C	Alarm when the air exhausting temperature reaches this set value.

STOP P.	1.00MPa	Alarm and stop the machine when the air supply temperature reaches this set value
MAX U.L.	0.80MPa	The Unload Limit Pressure in the Customer Parameter must be set lower than this value.
RUN TIME	****Hours	The manufacturer can modify the total running time
LOAD TIME	****Hours	The manufacturer can modify the load running time
CLR FAULT	****	Input the history failure password to clear all the history failures.
CUR UN.BAL.	0006	When (the max. phase current / min. phase current) is not greater than (1+set value), the unbalance protection will stop the machine. If the set value is greater than 15, the unbalance protection will be unavailable.
LACK PAHSE	005.0	If set time of phase failure $\geq 20$ seconds, phase failure doesn't function; If unbalance protection is activated, it will stop operation.
DATA	****_**_**	The manufacturer input the product date of the unit.
SERIAL	*****	The manufacturer input the product No. of the unit
PHASE PRO.	ON/OFF	ON:Select sequence protection OFF:Not select sequence protection
POWER FREQ	50H	Set the power frequency
HIGH VOL.	****V	Controller detects the voltage higher than the set value, the shutdown protection, reported voltage is too high. Set this value to 0000, the high voltage function is no function
LOW VOL.	****V	Controller detects the voltage lower than the set value, the shutdown protection, reported voltage is too low. Set this value to 0000, the low voltage function is no function
LOW T PRO-	-48°C	Controller detects the temperature is lower than this value, display temperature is too low, not allowed to start the air compressor
TIME LIM	0000H	When the compressor run time is greater than TIME LIM set, the controller will stop the compressor and alarm ; If the value set as '0000' the function is disable.
ALM STOP	0010H	Warning time over here to set, compressor report "warning too long" and stop
COM SET PARA	ON/OFF	
PARA1	****	

## 9、Calibration parameters

Calibration parameter used to set the controller data, Does not allow unauthorized users to view and modify

PARAMETER		Initial Value	Functions
M O T O R	TARGET CUR	0000	Enter the current value, the controller will detect user input value divided by the current to the current value, calculate the current coefficient
	COEF	1.000	Calibration current, the input coefficients.

A			Controller displays the current value = sample value x COEF
	CUR	***.*A	Displays the current controller sampling current values. This value is the real value can not be set.
M O T O R	TARGET CUR	0000	Enter the current value, the controller will detect user input value divided by the current to the current value, calculate the current coefficient
	COEF	1.000	Calibration current, the input coefficients. Controller displays the current value = sample value x COEF
	CUR	***.*A	Displays the current controller sampling current values. This value is the real value can not be set.
M O T O R	TARGET CUR	0000	Enter the current value, the controller will detect user input value divided by the current to the current value, calculate the current coefficient
	COEF	1.000	Calibration current, the input coefficients. Controller displays the current value = sample value x COEF
	CUR	***.*A	Displays the current controller sampling current values. This value is the real value can not be set.
F A N A	TARGET CUR	0000	Enter the current value, the controller will detect user input value divided by the current to the current value, calculate the current coefficient
	COEF	1.000	Calibration current, the input coefficients. Controller displays the current value = sample value x COEF
	CUR	***.*A	Displays the current controller sampling current values. This value is the real value can not be set.
F A N B	TARGET CUR	0000	Enter the current value, the controller will detect user input value divided by the current to the current value, calculate the current coefficient
	COEF	1.000	Calibration current, the input coefficients. Controller displays the current value = sample value x COEF
	CUR	***.*A	Displays the current controller sampling current values. This value is the real value can not be set.
F A N	TARGET CUR	0000	Enter the current value, the controller will detect user input value divided by the current to the current value, calculate the current coefficient

C	COEF	1.000	Calibration current, the input coefficients. Controller displays the current value = sample value × COEF
	CUR	***.*A	Displays the current controller sampling current values. This value is the real value can not be set.

## 10、 the operating authority and password

Controller provides multiple passwords and access management, according to different levels of passwords, providing different levels of operating authority, different levels of passwords and permissions as follows:

1. user's password: fixed as : \_\_\_\_\_  
Permissions: allows to modify the load pressure unload pressure, fan start temperature, fan stop temperature, start and stop mode, loading method, communication mode, communication address and linkage parameters.
2. User Password: set as: \_\_\_\_\_
3. Permissions: Allows to modify all user parameters.
4. manufacturers sales password: this password can be modify, set to : \_\_\_\_\_  
Permissions: Allows users to modify all the parameters, the user password, and the parameters of some manufacturers, manufacturers selling password.
5. manufacturers Password: factory fixed: \_\_\_\_\_  
Permissions: Allows users to modify all the parameters, the user password, and the parameters of some manufacturers, manufacturers selling password.
6. Calibration Password: set as: \_\_\_\_\_  
Permissions: allows you to modify the current parameters of the calibration parameters
7. Super Password: set as: \_\_\_\_\_  
Permissions: Allows users to modify "run time " "phase sequence protection " "power frequency " "max run time"

## 2、 Technical parameters and functions

- 1、 Digital input: Digital input of 3# circuit; digital output of relay of 5# circuit;
- 2、 Simulation quantity: Pt100 temperature input of 1# circuit; 4~20mA input of transducer of 1# circuit; two groups of three phase current input(CT provided);
- 3、 Input voltage of phase sequence: three phase 380V/220V;
- 4、 Controller's power supply: AC20V、 50Hz、 10VA;
- 5、 Measurement range displayed:
  - ①、 Oil temperature:-50~150℃; precision: ±1℃.
  - ②、 Air temperature:-50~150℃; precision: ±1℃.
  - ③、 Operation time: 0~999999 hours.
  - ④、 Measurement range displayed for current:0~999.9A.
  - ⑤、 Pressure: 0~1.60MPa. Precision: 0.01Mpa.
- 6、 Phase-sequence protection: When protector inspects wrong phase, response time≤2s (optional);
- 7、 Protection of motor: this controller has five basic protection functions for main motor and fan's motor

- ①、block protection: When working current reaches to from 4 times to 8 times of set current after finish starting, response time  $\leq 0.2s$ ;
- ②、Short circuit protection: when testing current reaches above 8 times of set current, response time  $\leq 0.2s$ ;
- ③、Protection of phase failure: in case of phase failure of any one phase, operation time equals setup time;
- ④、Unbalance protection: when currents of any two phase differ 60~75%, operation time equals set time;
- ⑤、Protection characteristics of reverse time limit of overload (time unit: second), please see following

table (table 2.1.1),  $multiple = I_{actual} / I_{set}$

motor operates with delay time according to overload factors and operation time shown in following table (table 2.1.1) when motor's working current is larger or equal to from 1.2 times and 3.0 times of set current.

$I_{actual}/I_{set}$	$\geq 1.2$	$\geq 1.3$	$\geq 1.5$	$\geq 1.6$	$\geq 2.0$	$\geq 3.0$
Time parameters						
Operation time (S)	60	48	24	8	5	1

Table 2.1.1 curve table of reverse time limit for protection of motor

- 8、Temperature protection: when actual temperature measured is larger than temperature set; response time  $\leq 2s$ ;
- 9、Contact capacity of output relay: 250V,5A; Contact endurance 500000 times
- 10、Error of displayed current is less than 1.0%.
- 11、RS485 communication

### 3、 Type and specification

#### 1、 Instruction of type

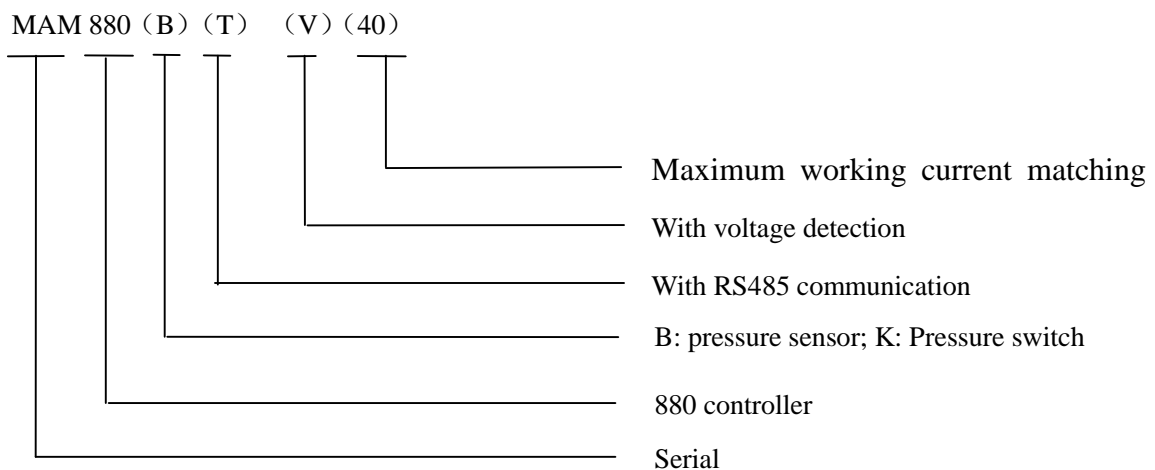

#### 2、 Specification table for power of suited motor

Parameter Specification	Current range (A)	Suited main motor power (KW)	Remark	Description
MAM880 (20)	8~20	4~10		Fan has three levels of current, such as 0.2-2.5A, 1-5A and 4-10A, determined according to fan's current
MAM880 (40)	16~40	8~20		
MAM880 (100)	30~100	15~50		
MAM880 (200)	80~200	40~100		
MAM880 (400)	160~400	80~200		
MAM880 (600/5)	100~600	50~300		

## 4、 Installation

### 1、 Installation of transducer

The transducer shall be installed at place where motor's line current (rated current) can be measured, thus controller can be set according to instructions on motor's name plate, the detailed dimensions as followed:

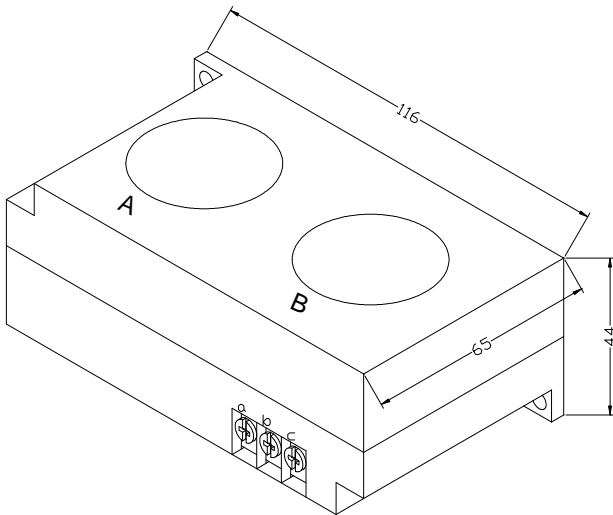

Figure 4.1.1. Structural dimensions of CT1 (φ36 through hole)

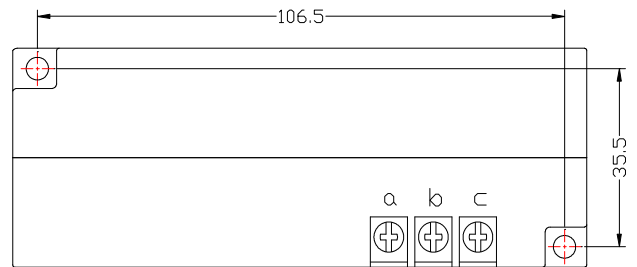

Figure 4.1.2. Install dimensions of CT1

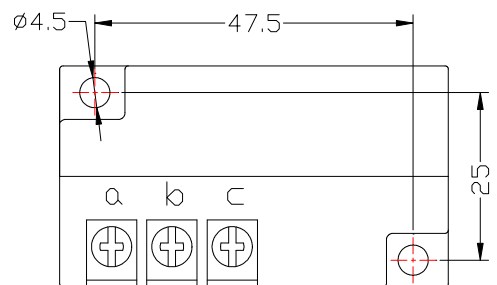
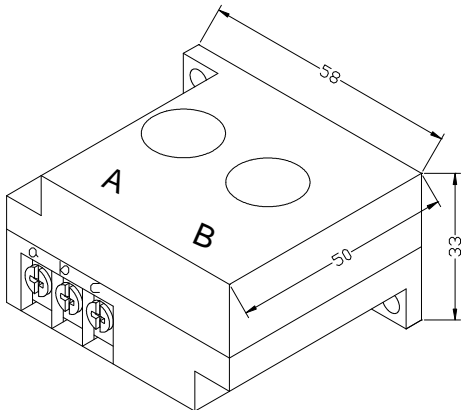

Figure 4.1.3. Structural dimensions of CT2 ( $\phi 10$  through hole)

Figure 4.1.4. Install dimensions of CT2

## 2、Controller Installation

The controller is installed as plate. Room should be left around controller for wiring. The specific dimensions are as follows:

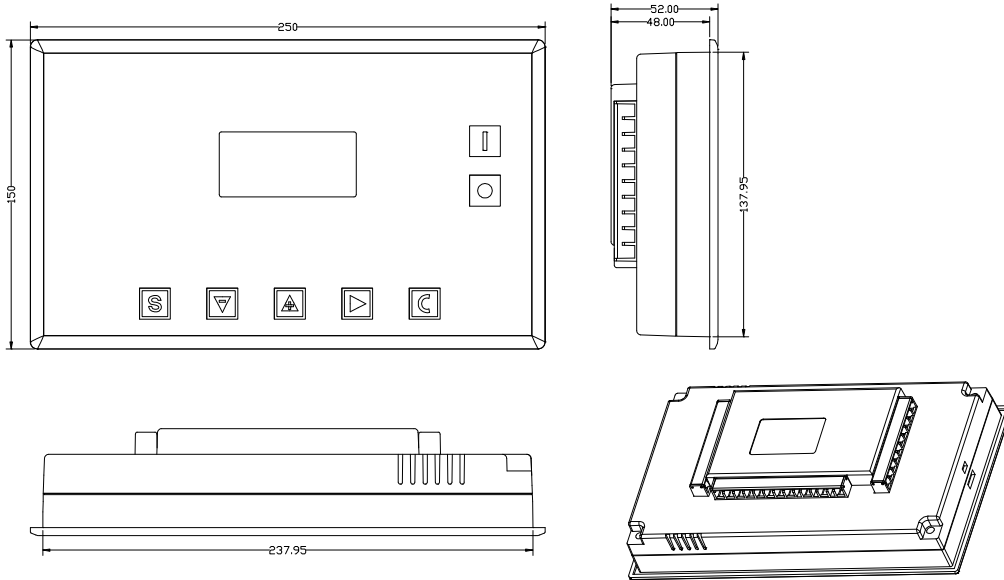

Figure 4.1.5 Controller structure dimensions

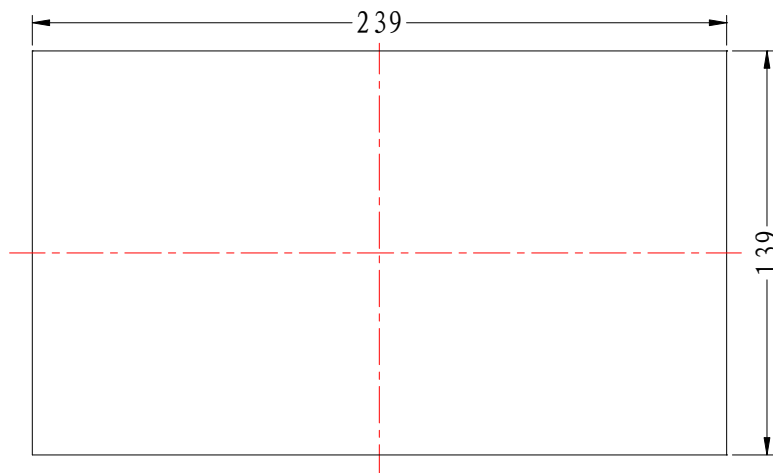

Figure 4.1.6 Hole size

## 3、Terminal arrangement diagram

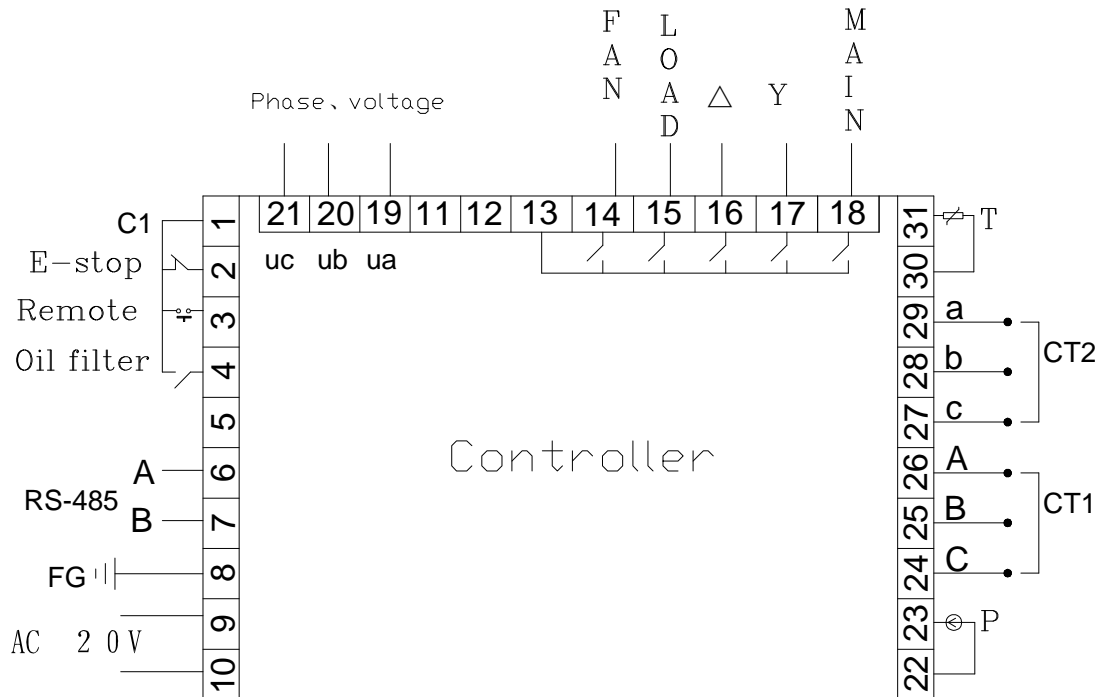

Figure 4.2.1 Terminal arrangement diagram

Terminal blocks of controller:

1 is common terminal COM1; 2 is input terminal for emergent stop signal; 3 is remotely controlled for on/off signal input terminal; 4 terminal is used to detect oil filter blocked; 6 is RS485 A; 7 is RS485 B; 8 is the simulated ground (Earth); 17 and 18 are the AC20V power source; 22、23 terminals are Pressure Sensor signal input; 24、25、26 terminals are motor mutual inductor CT1 input; 27、28、29 terminals are Fan mutual inductor CT2 input; 30、31 terminals are Temperature Sensor signal input; 19、20、21 terminals Used to detect the phase sequence and voltage; 13 terminals is common terminal of output relay; 14 terminals controls fan; 15 terminals controls load valve; 16 terminals controls angle-shaped contactor; 17 terminals controls star-shaped contactor; 18 terminals controls main contactor.

**NOTE: Electromagnetism coil shall be connected with surge absorber during wiring, and dotted lines are extendable functions.**

## 5、 Control principles

### 1、 Local Automatic control

#### ①. press down start button for starting: (Y- $\Delta$ start)

There is five seconds of self-test after controller is energized and it can not be started by pressing start button. The air compressor starts by pressing start button after self-test finished. The course of compressor's start as followed: KM3 and KM2 are energized  $\rightarrow$  Y-type status of start  $\rightarrow$  delay time is reached (Y- $\Delta$ change-over time); KM3 is de-energized (KM1 and KM3 are interlocked) and KM1 is energized  $\rightarrow$  motor operates with  $\Delta$  type to finish start. During the course of starting, all electromagnetism valves are de-energized to achieve no load start.

#### ②. Automatic operation control:

When the motor is started to running in  $\Delta$  status and load the magnetic valve with



power applied after a certain period of delay. air compressor is loaded and pressure inside gas tank begins to increase. When increased air pressure is more than higher pressures limit (value of unload pressure), electromagnetism valve for loading is de-energized and electromagnetism valve for discharging is energized, meanwhile, the air compressor operates without load. If air pressure decreases to set lower pressure limits (value of load pressure), the electromagnetism valve for loading is energized again and electromagnetism valve for discharging is de-energized. Air compressor operates normally to increase pressure in air tank. If the unload run time exceeds the set delay time of non-load, the compressor will automatically stop motor's operation to achieve automatic shutdown after works without load for long time. Only when pressure decreases to lower pressure limits, the motor start operation according to course of starting, then circularly repeat this step.

### ③. Manual loading/unloading under automatic status

When compressor in automatically runs state and runs at unload operation, press down load or unloading button , the electromagnetism valve for loading joggles a little and comes back to unloading status; if the pressure is less than relief pressure, the electromagnetism valve for loading is energized and it returns to unloading status until gas supply pressure becomes larger than relief pressure and device is at loading status. Unloading is performed when press down unloading button “S”. If the pressure is higher than loading pressure, the electromagnetism valve for loading is de-energized and turns to status of loading until gas supply pressure is less than loading pressure. If pressure is less than loading pressure, the unloading button do not function.

### ④. Normal shutdown:

Press the button , the load magnetic valve will loss power and the unload magnetic will be applied with power, after a while of delay (stop delay), the motor contactor will loss power, the host and fan will stop running, after the restarting delay completed, the unload magnetic will loss power. Only pressing the button could restart the motor.

### ⑤. Control of preventing frequent starting

Press stop button to stop operation; Air compressor can not be started up immediately after shutdown due to operation without load for long time or failure shutdowns, and it can be started up again when remaining delay time is zero which the time display window of the controller in a variety of shutdown state shows.

## 2、. Remote automatic control

Remote automatic control and local automatic control are basically same, but the difference is that starting up or stopping of devices can be achieved by means of control of remote switch.

## 3、 Local manual control

Control of starting and stopping are same as automatic control, but device is in status of unloading operation after finish starting up and loading is carried out by pressing down loading and unloading button to load. When gas supply pressure is more than relief pressure, the device unloads automatically. If doesn't press loading, unloading button, the device will operate with unloading until stops without load. During unloading, press loading and unloading button to load. During loading, press loading and unloading button to unload.

## 4、 Remote Manual Control

The remote automatic control is almost the same as the local manual control, the only difference is that the start and stop of the unit is controlled by remote control.

## 5、 Network control

- ①: When communication method is set “computer”, network control between computer and controllers can be achieved
- ②: When communication method is set “interlocking”, network control between controllers can be achieved, but the main air compressor only can service as 1# compressor.

## 6、 Temperature control of fan

When exhausting temperature is higher than fan’s starting temperature, fan operates; when exhausting temperature is lower than fan’s stopping temperature, fan stops operation.

## 7、 Failure shutdown and emergency shutdown

When electrical failure or high exhausting temperature appears during process of operation, the controller stops motor’s operation immediately. Air compressor only can be started up after failure is eliminated. In case of emergency, press down emergency stop button to cut off power of controller and contactors

# 6、 Early-warning and prompts

## 1、 Indication of early warning of oil filter

- ①. Early warning for blockage of oil filter

The controller can display the message on the text display to remind the operator that “ the air filter is blocked” by checking the pressure difference switch operating state.

- ②. Set the running time alarm of the air filter

The Text displays “OIL FILTER LIFE END” when the using time of the oil filter terminates.

## 2、 Indication of early warning for air filter

The Text displays “AIR FILTER LIFE END” when the using time of the oil filter terminates.

## 3、 Indication of early warning for oil separator

The Text displays “**O/A LIFE END**” when the using time of the oil separator terminates.

## 4、 Indication of early warning for lubricating oil

The Text displays “**LUBE LIFE END**” when the using time of the lube terminates.

## 5、 Indication of early warning for grease

The Text displays “**GREASE LIFE END**” when the using time of the grease terminates.

## 6、 Indication of early warning for belt

The Text displays “**BELT LIFE END**” when the using time of the belt terminates.

## 7、 High air temperature warning

Controller detects the air temperature high, the text display “HIGH TEMPERATURE”

## 7、 Controller protection

### 1、 Motor protection

MAM-880 air compressor controller provides all-round protection functions of short-circuit, locking, phase failure, overload, imbalance for motor.

Electronic failure	Failure Display	Reason
Short circuit	Display failure “HOST/FAN SHORT”	Short circuit or rated current is set by mistake
Blocked	Display failure “HOST/FAN BLOCK”	Too large load, bearing wear and other mechanical failure
Overload	Display failure “HOST/FAN OVER CARRY”	Too large load, bearing wear and other mechanical failure
Phase failure	Display failure “HOST/FAN LACK PHASE”	Power supply, contactor and phase failure of motor
Unbalance	Display failure “HOST/FAN UNBLANCE”	Poor contact of contactor, inside open-loop of motor

### 2、 Gas Exhaust Over-temperature Protection

When the Air exhaust temperature is higher than the upper limit of set temperature, the controller would be stopped ,The display will show “**HIGHT T**”.

### 3、 Non-reversing Protection of Air Compressor

When three-phase supply phase sequence connected to the air compressor is not the same with that set for the controller, the on-site failure is displayed as “**PHASE REVERSAL**”, as a result, the controller cannot start up the motor. Then just change any arbitrary two-phase power lines leading to check the rotation of motor.

### 4、 Overpressure Protection of Pressure Supply

When the gas exhaust pressure is higher than the upper limit of set pressure, the controller would be stopped for warning, the on-site failure is displayed as “**HIGH P**”.

### 5、 Malfunction Protection of Sensor

When pressure sensor or temperature sensor is disconnected, the controller would be stopped for warning. the on-site failure is displayed as “**\*\*\*SENSOR FAULT**”.

## 8、 Removal of Common Failures

### 1、 Failures Review

Shutdown caused by the external parts of controllers may be removed by inquiring the on-site failure or historic failure, with the details shown as below:

Press Down button or Up button , to move the black scroll bar to “**RUN PARAMETER**” menu, then press Enter button , the lower menu would be propped out:

<b>MOTORS CURRENT</b> TOTAL RUN TIME THIS RUN TIME MAINTENANCE SET
---

Press Down key always and the following menu will appear:

HISTORY FAULT PROD DATE NO. <b>THIS FAULT</b>
---

Press Enter key and the following failure causes will appear:

STOP:T1 SENSOR FAULT 0170°C
--------------------------------

In this case, just check if the temperature sensor is disconnected and if the sensor is damaged, etc.

## 2、 Common Failures and Causes

<b>Failure</b>	<b>Reason</b>	<b>Disposal method</b>
Air Exhaust Temperature too high	Bad vent condition, Oil lacking etc.	Check the vent condition and lubricant amount etc.
Temperature Sensor Failure	Cable off or PT100 damaged	Checking the wiring and PT100
Over Pressure	The pressure too high or the pressure sensor failure	Check the pressure and the pressure sensor
Pressure Sensor Failure	Cable off, Sensor damaged or the cable connected reversed	Check the wiring and sensor transformer
Lack Phase	Power phase lacking or the Contactor terminal damaged	Check the power and contactors
Overloaded	Voltage too low, tubes blocked, Bearing Wear off or other mechanical failure or wrong set data etc.	Check the set data, Voltage, bearings, tubes and other mechanical system.
Unbalance	Power unbalance, Contactor damaged or the internal open of the motor	Check the power, contactors and the motor
Rotor Lock	Voltage too low, tubes blocked, Bearing Wear off or other mechanical failure or wrong set data etc.	Check the set data, Voltage, bearings, tubes and other mechanical system.
Short Circuit	Wrong Wiring, Incorrect Data setting etc.	Checking the wiring and set the data correctly
Wrong Phase Sequence	Reversed Phase sequence or phase off	Check the wiring
Overload or Rotor locking during starting	Host start time set to a valueless than the star angel time delay	Reset the host starting time to be longer than star angel delay + Load delay time

process		
Main Contactor activate time to time	The emergency button loose	Check the wiring
Air Exhaust Temperature too high	Bad vent condition, Oil lacking etc.	Check the vent condition and lubricant amount etc.
Temperature Sensor Failure	Cable off or PT100 damaged	Checking the wiring and PT100
Over Pressure	The pressure too high or the pressure sensor failure	Check the pressure and the pressure sensor

# 9、Electrical diagram

